

5 Palletizing and Roll Angles

NAME: _____ Date: _____ Section: _____

INTRODUCTION

Have you ever wondered why most consumer goods are delivered to your doorstep in rectangular boxes? Think about the shape of the truck they were delivered in. Or the shape of the boxcar or shipping container that they left the factory in. Most consumer goods are moved around on pallets that are rectangular as well.

In this activity you will learn how to palletize rectangular containers. Think about it... every time you move a rectangle from one point to another, there is a good chance that the edges will not line up. In this activity, you will learn how to calculate the amount you need to turn the boxes (**ROLL ANGLE**) to place them on a pallet properly. You will also learn how to make a robot perform the process called

PALLETIZATION.



KEY VOCABULARY

- Pallet
- Roll Angle
- Palletization
- Pitch
- Yaw

EQUIPMENT & SUPPLIES

- Robot Magician
- Dobot Field Diagram
- Four or more $\frac{3}{4}$ " cubes
- Pneumatic Gripper
- Jumper wire
- Suction Cup Gripper
- DobotStudio software
- Input switch
- 4.7 k Ω Resistor
- 2 Servo extension cables
- Electrical tape

PROCEDURE

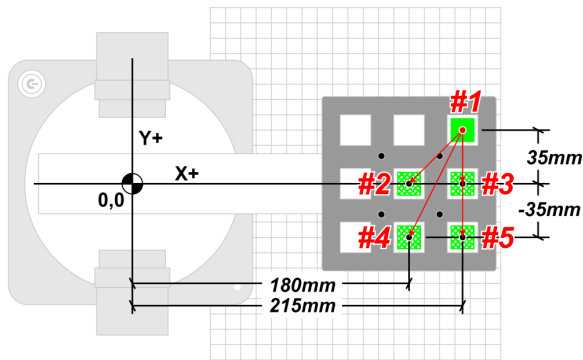

In this activity, you are going to make the Dobot complete the following task:

- Human places a cube at the START Position #1.
- When the input switch is pressed, the robot picks the block up from Position #1 and places it at Position #5.

Repeat the process of

- Manually replacing a cube at Position #1
- Pressing the Limit Switch
- Taking the cube from Position #1 and placing the cube at Position 4, 3, and 2.



Caution: NEVER wire anything to the Dobot Magician while it has power on. ALWAYS turn it off before making connections or damage to the robot could occur. Be sure to ask your instructor if you have any questions.

- Wire the limit switch as done in previous activities and set up the robot and field diagram as shown.
- Using teach, record, and the *options* menu in the teaching *and playback* module of DobotStudio make the robot place the two parts on the pallet.

_____ Have your instructor check your work when finished.

- What is wrong with the placement of the objects? Why is this so?

- The software will calculate the roll angle for you relative to the first recorded position. In the following steps we are going to use math to calculate how the software derived these positions. After a demonstration by your teacher on how to do this, go ahead and calculate the angles in the problems below

Move the blocks from the common unload position (Position #1), to the finished pallet positions (Positions #2, 3, 4 & 5) as shown in the diagram below.

Manually replace the block in Position #1 for each pallet position.



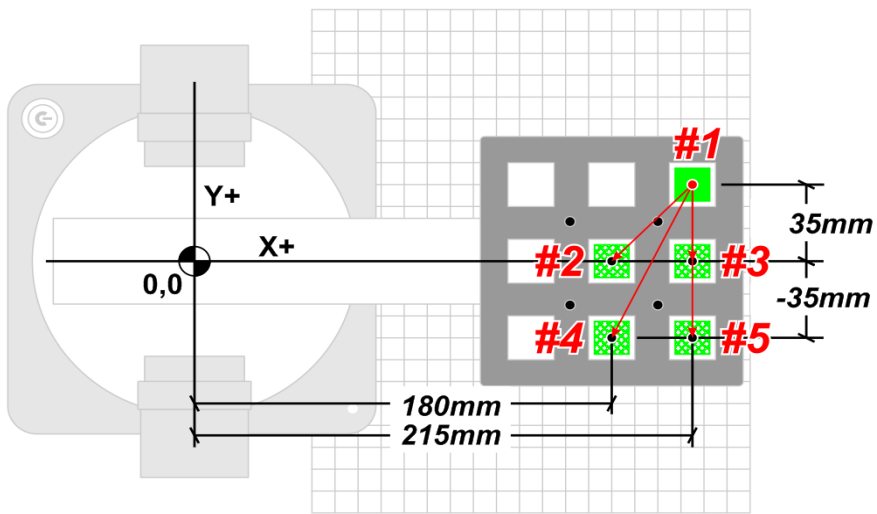

5. In the space provided below the diagrams, calculate the correct roll angle for positions 1 & 5 relative to the X axis. Show your work even though you are using a calculator.

Note that: $\tan = \text{Opp/Adj}$ and $= \tan^{-1}(\text{Opp/Adj})$

$$\theta_1^\circ = \tan^{-1}(\text{Opp/Adj})$$

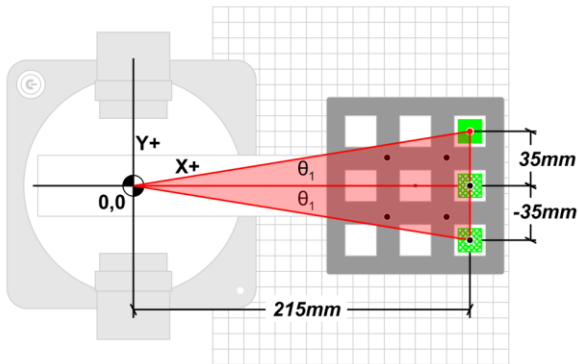

Calculation:

6. In the space provided above, calculate the correct roll angle for position 4. Show your work even though you are using a calculator.



$$\theta_1^\circ = \tan^{-1}(\text{Opp}/\text{Adj})$$

Calculation:

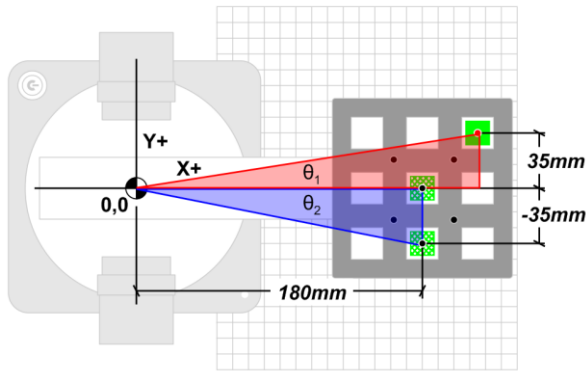
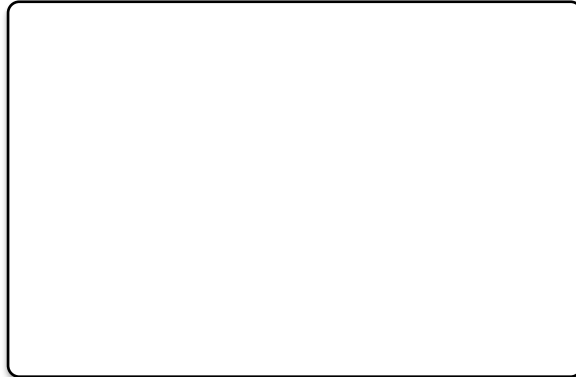

7. In the space provided above, calculate the correct roll angle for position 4. Show your work even though you are using a calculator.

8. In DobotStudio, the angle can be remembered and held from an original position. To do this we can have the software calculate the roll angle by changing the value in the R column for all the positions after the first one to zero "0".

X	Y	Z	R	PauseTime	Stat
8796	-2.317	18.4089	-30.6882	0.0	Suc
8796	-2.317	18.4089	-30.6882	0.0	Suc
8796	-2.317	18.4089	-29.7987	0.0	Suc
8796	-2.317	18.4089	-29.7355	0.0	Suc
3898	3.702	-36.0346	-29.1529	0.0	Suc



CONCLUSION

1. Pick another position off of the pallet, sketch the diagram in your notebook or on the field diagram and calculate the roll angle if the robot were to move a part there from position #1. be sure to show your work.
2. If you stacked another layer on top of the layer that is already on the pallet, would the roll angles change? Why or why not? Justify your answer.
3. If you swapped to the mechanical gripper, and touched up the points, would the roll angles still be correct? Why or why not? Justify your answer.
4. What is an advantage to a vacuum or suction gripper, when palletizing, over a mechanical gripper? Justify your answer.

GOING BEYOND

Finished early? Try some of the actions below. When finished, show your instructor and have them initial on the line.

- _____ 1. Change the gripper to the mechanical gripper and try to recreate this.
- _____ 2. Stack another set of blocks on top of the first set.
- _____ 3. Start with the pick spot off to the side of the pallet and fill a pallet with one layer.
- _____ 4. Complete a second layer after completing #3.

